

Wastewater Pumps

DanPumps S-WP0 - 50 Hz

Product Applications

S-WP0-37 is the smallest pump in the series and is especially suitable for pumping from cellars, pre-cleaned waste water or drain from parking plants. S-WP0-50 is constructed for waste water from one single household, washing plants, tunnels, big basement outfalls etc. S-WP0-65 is constructed for waste water where more households or companies are attached. The pump can be mounted on a base elbow. This model is also available as Grinder Pump.

Design

DanPumps S-WP0 are pumps for small tasks within the wastewater area. All pumps are characterized by a high quality and an exquisite material choice. The pump is supplied with a vortex impeller and a large free passage through the pump housing reducing clogging and prolonging the lifetime of the pump.

Materials

Pump Housing	Cast iron GG 25
Base elbow	Cast iron GG 25
Impeller high head	Ductile cast iron GGG-40
Pumping wheels	Cast iron GG 25
Shaft	Stainless steel AISI 420
Bolts	Stainless steel AISI 304
Primary shaft sealing	Silicon carbide / Silicon carbide
Secondary sealing	Graphite/aluminium
Cable	H07HNF
Motor	Insulation class H Protection degree IP68

Operation standards

- Connections up to DN65
- Flow Rate up to 68 m³/h
- Overheating protection
- Double mechanical shaft seal in oil bath
- High-efficient motors
- Over-dimensioned bearings ensure a long life of the pump
- Float switch regulator
- Easy maintenance



Performance Curves - DanPumps S-WP0 - 50 Hz

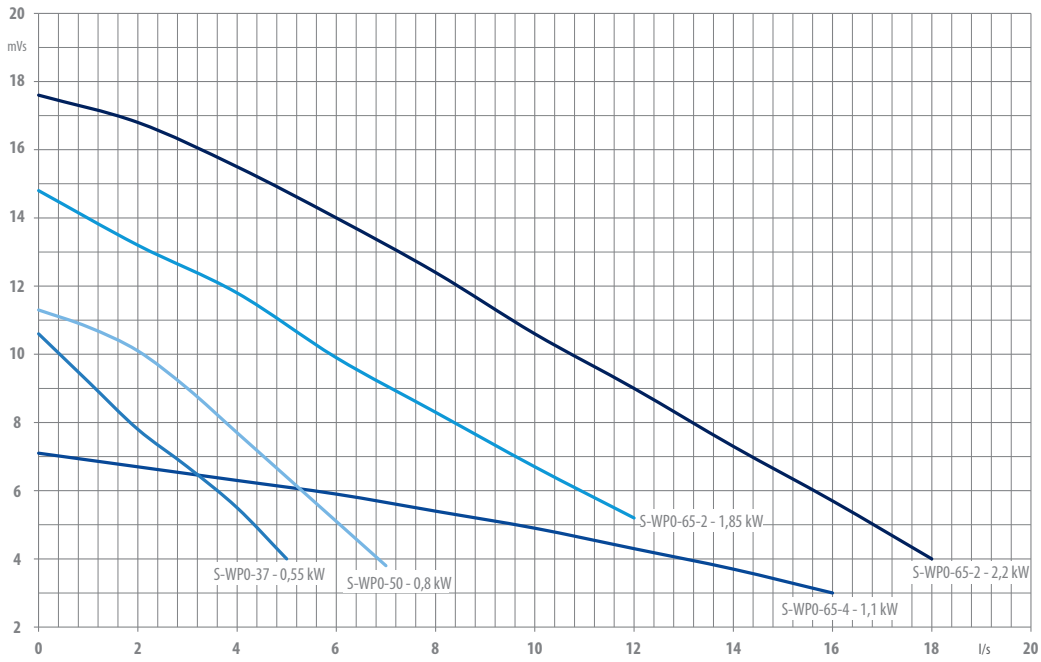

DCB DN-40 Installation Kit
S-WP0-37, Art. No: F070000100001
S-WP0-50, Art. No: F070000100002



DCB Installation Kit for S-WP0-65
 Article no.: 20210702

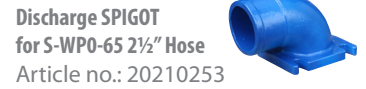

Discharge SPIGOT for S-WP0-65 2 1/2" Hose
 Article no.: 20210253



Threaded Flange Kit for S-WP0-65 2 1/2"
 Article no.: 20200112

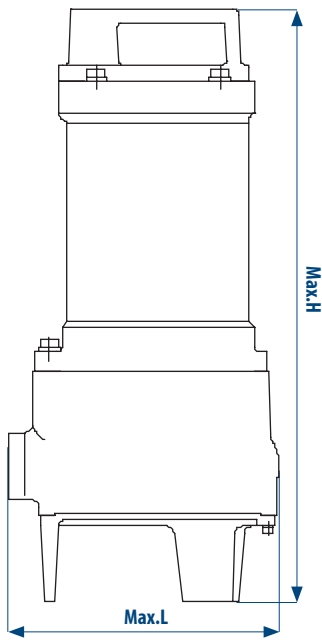

DanPumps S-WP0-37

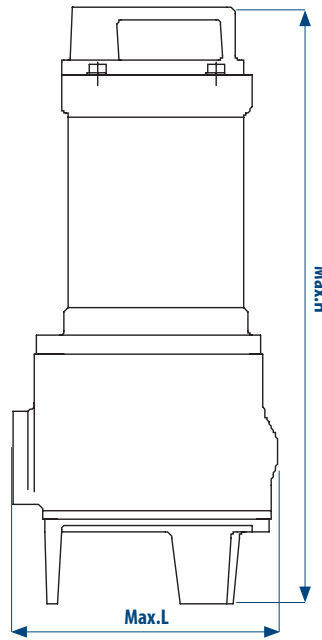

DanPumps S-WP0-50

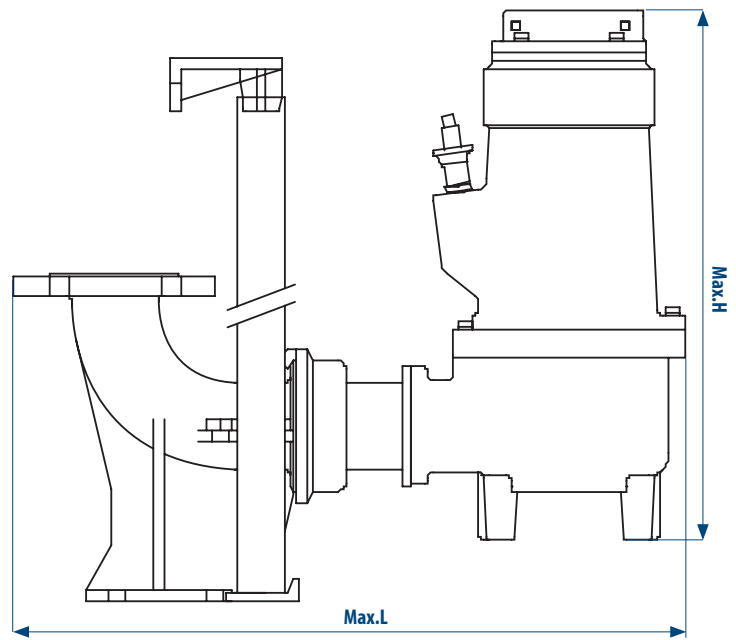

DanPumps S-WP0-65
 Also available as Grinder Pump

Type	kW P2	Rpm	Outlet flange
S-WP0-37	0,55	2850	1 1/2"
S-WP0-37	0,55	2850	1 1/2"
S-WP0-50	0,8	2850	2"
S-WP0-50	0,8	2850	2"
S-WP0-65-2	1,85	2850	DN65
S-WP0-65-2	2,2	2850	DN65
S-WP0-65-4	1,1	1450	DN65

Type	Max. Height	Max. Width	Max. Length
S-WP0-37	350	150	160
S-WP0-37	350	150	160
S-WP0-50	425	165	190
S-WP0-50	425	165	190
S-WP0-65-2	549	220	616
S-WP0-65-2	549	220	616
S-WP0-65-4	549	220	616

All dimensions are in mm.



DanPumps A/S
 Nordager 25
 DK-6000 Kolding
 Denmark

Tel. +45 8657 1344
 info@danpumps.dk
 www.danpumps.dk

Copyright © 2013 DanPumps A/S - DanPumps cannot be held responsible for possible errors in catalogues, brochures or other printed materials. DanPumps A/S reserves the right at any time to change the specifications without notice.